

DP200 - PERFORMER SERIES

TECHNICAL DATA

	METAL	PLASTIC
PRESSURE RATIO	1:1	1:1
MAXIMUM FREE DELIVERY	200 l/min (53 gal/min)	200 l/min (53 gal/min)
AIR PRESSURE OPERATING RANGE	1,5 to 8 bar (22 to 120 psi)	1,5 to 8 bar (22 to 120 psi)
SOLIDS IN SUSPENSION MAXIMUM SIZE	6 mm (1/4")	6 mm (1/4")
MAXIMUM DRY SUCTION LIFT	5 m (16')	5 m (16')
MAXIMUM WET SUCTION LIFT	8 m (26')	8 m (26')
FLUID INLET AND OUTLET CONNECTIONS	1" BSPP (F)	1" Flange
AIR INLET CONNECTION	3/8" NPSM (F)	3/8" NPSM (F)
AIR VALVE	Frictionless Pivot Valve	Frictionless Pivot Valve
WEIGHT	11,5 kg (23.35 lb)	10,5 kg (23.15 lb)
OTHER WETTED PARTS	See available materials	See available materials

Very robust design for the toughest applications.

Recommended for some submersible applications and aggressive atmospheres.

PERFORMANCE CURVES

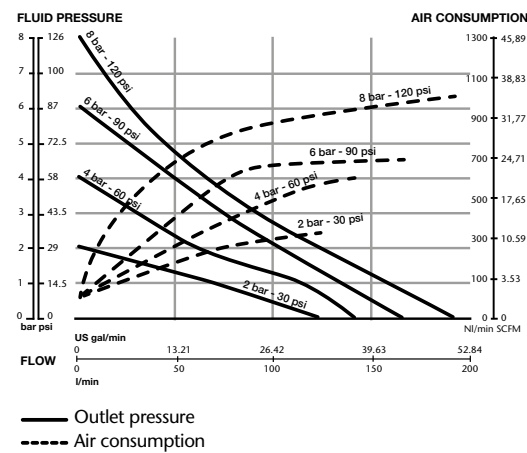

DIMENSIONS mm (inches)

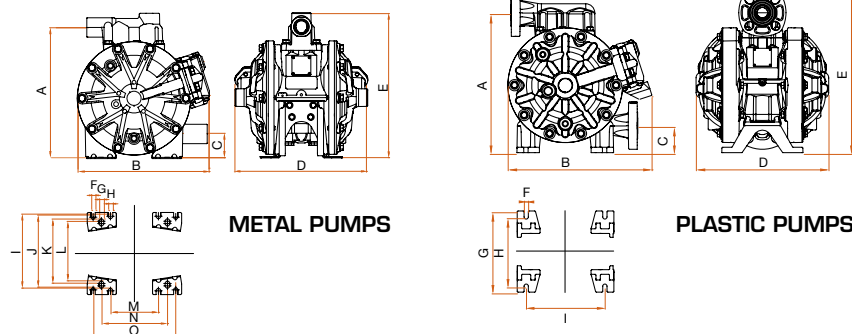

A	B	C	D	E	F	G/H
278 (11")	280 (11")	52 (2")	281 (11")	308 (12 2/16")	9 (11/32")	10 (13/32")
I	J	K	L	M	N	O
158 (6 1/4")	154 (6 1/16")	137 (5 13/32")	127 (5")	102 (4")	140 (5 1/2")	175 (6 7/8")

A	B	C	D	E
311 (12 1/4")	320 (12 19/32")	60 (2 1/3")	295 (11 2/3")	364 (14 1/3")
F	G	H	I	
9 (11/32")	180 (7 3/32")	154 (6 1/16")	175 (6 7/8")	

DP200 PUMPS
PERFORMER SERIES
Enhanced Leading Technology

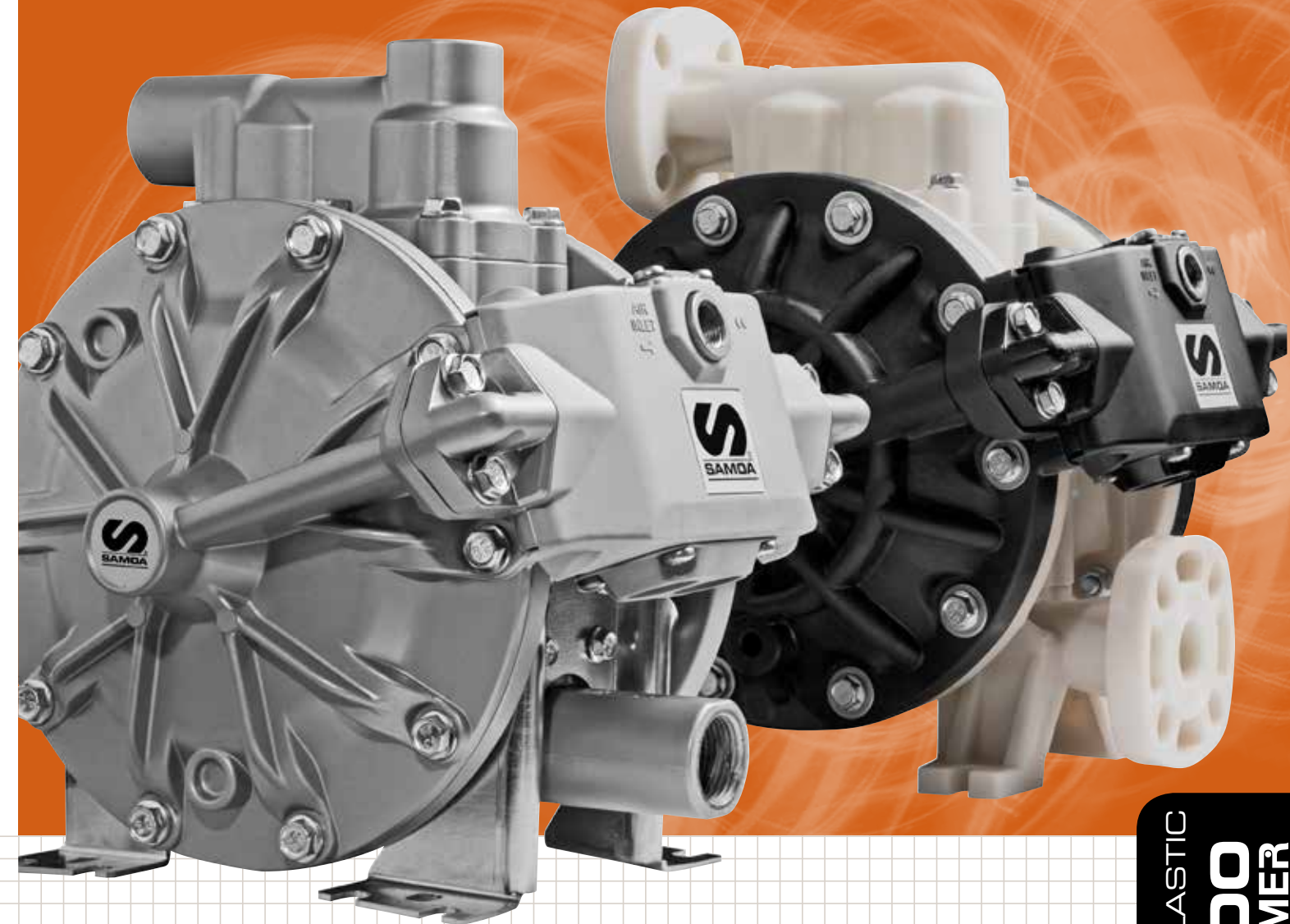

1" Air Operated Diaphragm Pumps

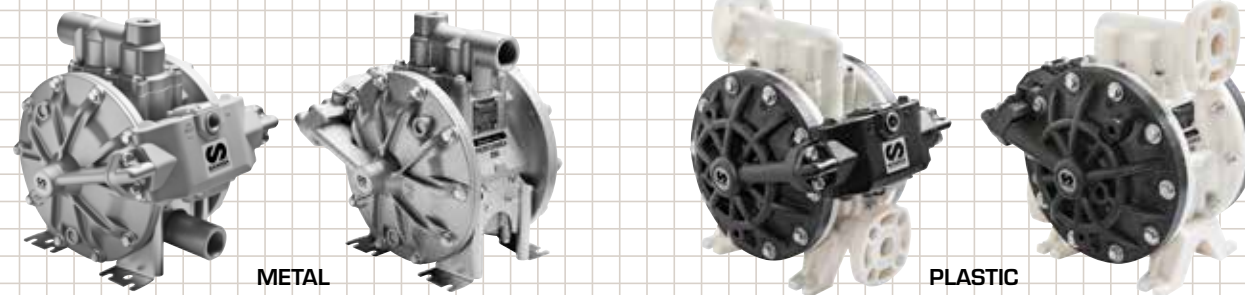

METAL

PLASTIC

METAL & PLASTIC
DP200
PERFORMER



SAMOA INDUSTRIAL, S.A. - HEADQUARTERS
Pol. Ind. Porceyo, 1-14 • Camino del Fontán, 831
E-33392 Gijón (Asturias) SPAIN
Tel.: +34 985 381 488 - Fax: +34 985 147 213
export@samoaindustrial.com • www.samoaindustrial.com

© Copyright, SAMOA Industrial, S.A.
SAMOA Industrial, S.A. is an ISO 9001, ISO 14001 and OHSAS 18001 certified company.



ventas@equinter.co

Móviles: 316 878 8696 - 316 877 3203

www.equinter.co

DP200 - PERFORMER SERIES

1" Air operated diaphragm pump.

The new SAMOA Directflo[®] 1" pump, DP200 Performer Series, is developed for maximum performance and efficiency, exceeding market expectations.

200 l/min
53 gal/min

DP200 - PERFORMER SERIES

1" Air operated diaphragm pump.

THE NEW PERFORMER SERIES MAKES THE DIFFERENCE THROUGH:

HIGHER EFFICIENCY. Maximum fluid flow with minimum air consumption.

INCREASED RELIABILITY. No stall, non icing, reliable start up and longer air valve and diaphragm life.

MAXIMUM VERSATILITY. Orientable inlet and outlet ports offer multiple mounting options and large material selection offers maximum fluid compatibility.

EASY SERVICING. Exclusive Directflo[®] central flow design allows fast servicing of diaphragms and air motor without dismantling it from the fluid line.

MAXIMUM PERFORMANCE

PERFORMER SERIES SETS NEW STANDARDS IN DIRECTFLO[®] TECHNOLOGY

- ▶ New check valve design.
- ▶ Improved air motor.
- ▶ Top and lower fluid manifolds.
- ▶ Orientable ports.
- ▶ One-piece diaphragms.

- Higher suction capacity.
- Reduced air consumption.
- Shorter strokes.
- Quiet operation.
- Extended diaphragm life.
- Better resistance to abrasion.
- Less stress on parts.
- Minimum pulsation and vibration.

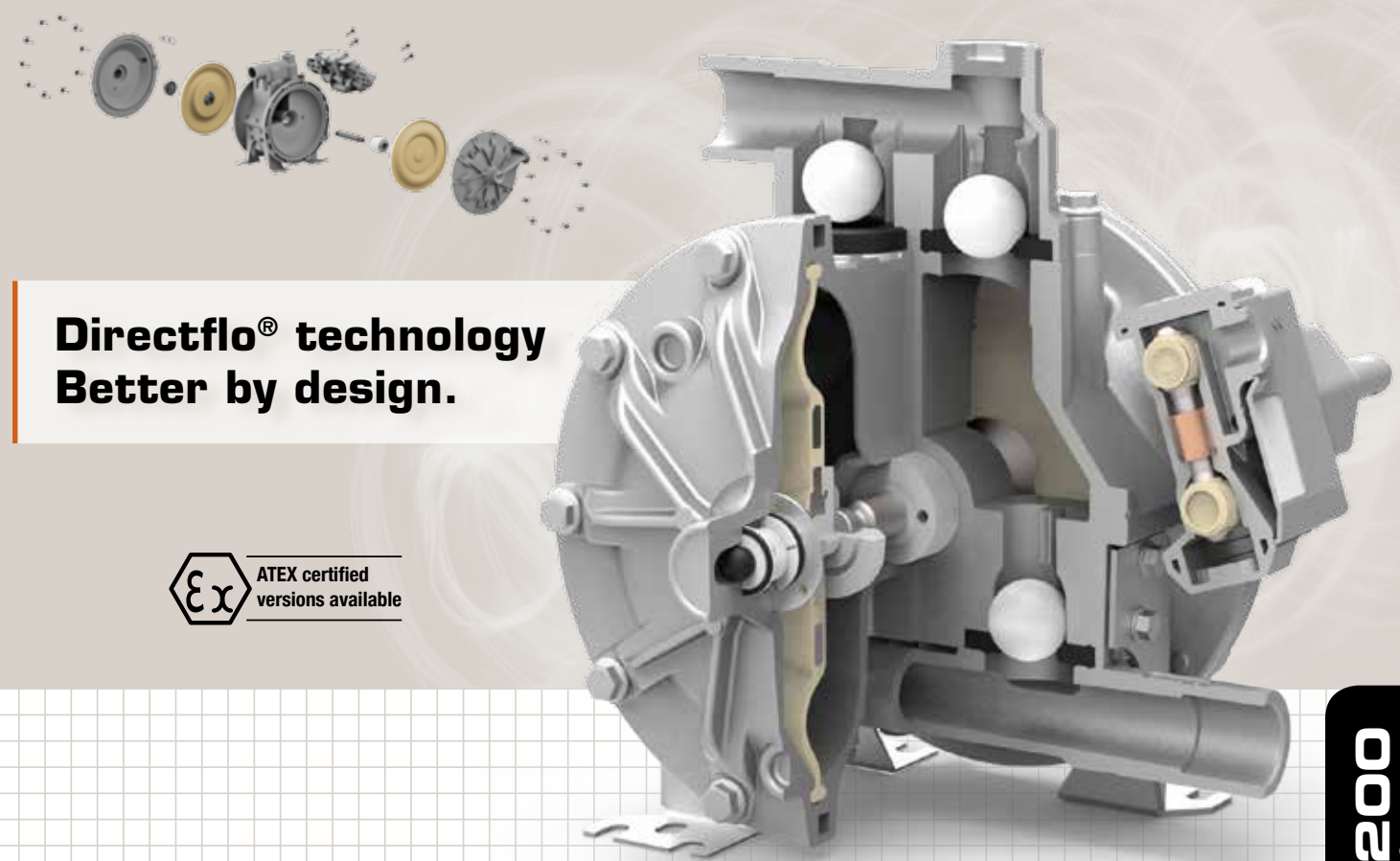
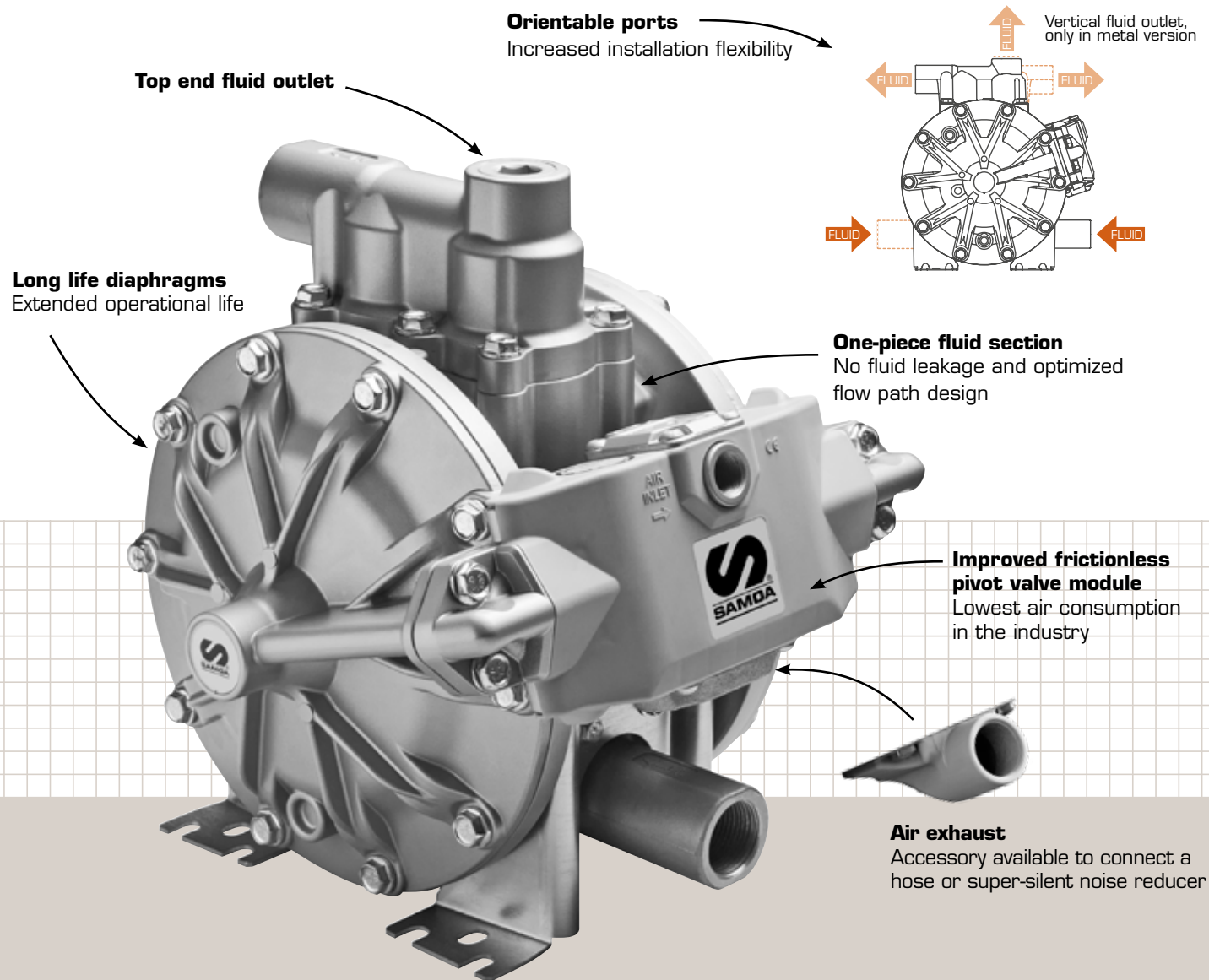

Directflo[®] technology
Better by design.

ATEX certified
versions available

MODELS AVAILABLE

PUMP SIZE	PART NUMBER	PUMP BODY	DIAPHRAGMS	BALLS	OTHER WETTED PARTS	APPLICATIONS
DP200 METAL PUMP (200 L/MIN)	555 010	Aluminium	TPE	Acetal	Buna-N, Stainless steel	Antifreeze and windshield wash solutions, lubricants, diesel
	555 030	Aluminium	Buna-N	Acetal	Stainless steel	Special for waste oil and diesel evacuation ⁽¹⁾
DP200 PLASTIC PUMP (200 L/MIN)	555 164	Polypropylene	TPE	PTFE	FKM, Stainless steel	Antifreeze and windshield wash solutions, AdBlue [®] /DEF

⁽¹⁾ Some types of diesel include additives in their formulation that might not be compatible with Buna-N.

Wall mount bracket (Part No.: 360 142)

Exclusive Directflo[®] pump technology.

PROVEN SUPERIOR PERFORMANCE | SIMPLE | RELIABLE | DURABLE | COMPACT | SMOOTH RUNNING | COST EFFICIENT